

High Quality Laundry Equipment



Powder proportioning systems for continuous batch washers and washer extractors

EDOS 200



EDOS 200 mit Big-Bag



EDOS 1000/500



Description EDOS 200

- Automatic dosage of detergents for continuous batch washers and washer extractors
- Up to 8 washing machines can be connected.
- Storage reservoir with a capacity of ca. 22 or 56 liters.
- Devices available with or without big bag system (max. 250 kg carrying capacity).
- The powder in the storage reservoir is proportioned by a rotating star shaped dosing disc either as pulsatile dosing or time-dependent.
- During dosage the powder trickles into funnel water washed round and is then solved into water.
- The detergent caustic solution is supplied by a high-grade steel lye pump.

EDOS 1000/500

- Tribe lye container for liquid detergents and strength
- Direct HD heating for a fast heating and/or intermixture and indirect heating to hold the temperature.
- Complete with agitator, centrifugal pump, rotary pump, level indicator, electronic control.

Technical data: EDOS 200

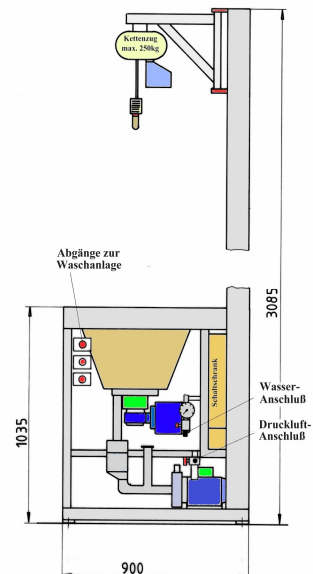
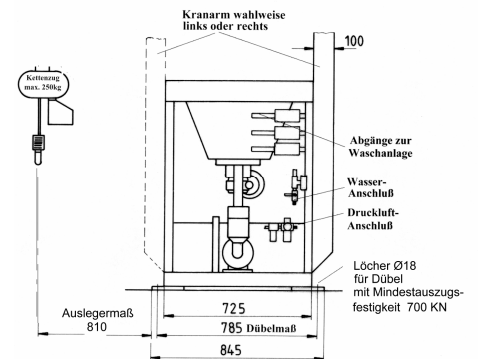

El. connection:	400V, 50 Hz
	2,3 KW –
Water connection:	1/2“
Compressed air:	1/4, 8 bar
Weight:	200 kg
	mit Big-Bag

EDOS 1000/500	
Container volume:	1000/500 Liter
Container diameter:	1260/890 mm
Steam connection:	DN 25, 4 bar
Water connection:	1/2 “
Power connection:	400 V, 50 Hz
	ca. 6 KW
Container material:	High grade steel
Empty weight:	ca. 150 kg